





--	--	--	--

Range Of Spectral Bandwidth						
Wavelength Of Peak Sensitivity						
					μ	= 1K
					μ	
						p=940nm

1.

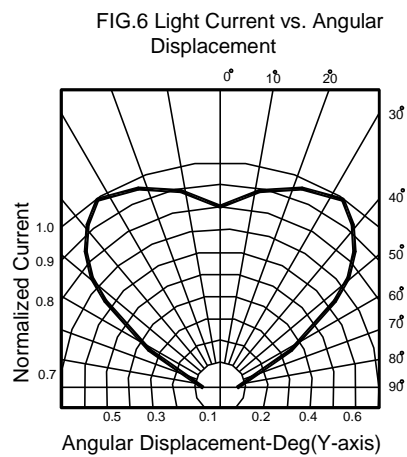
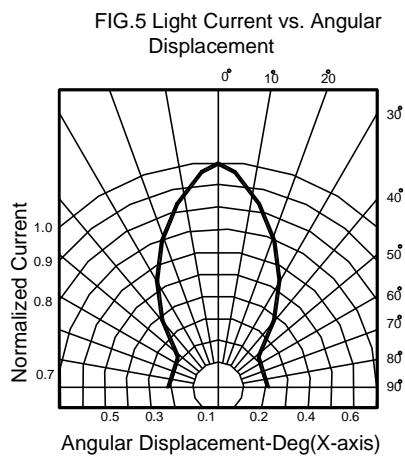
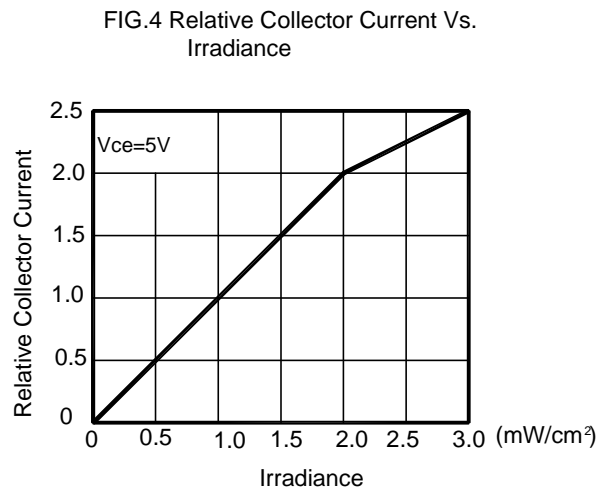
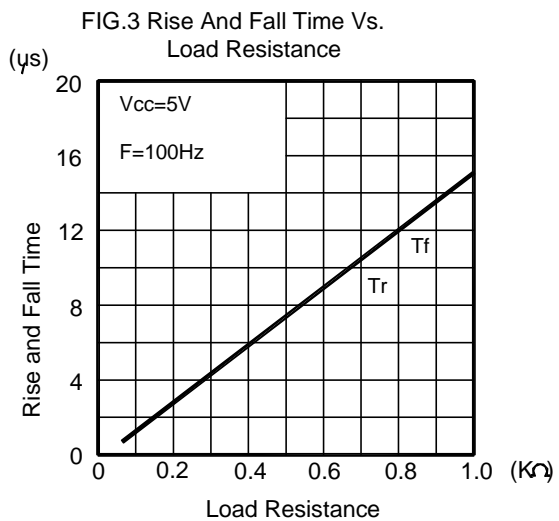
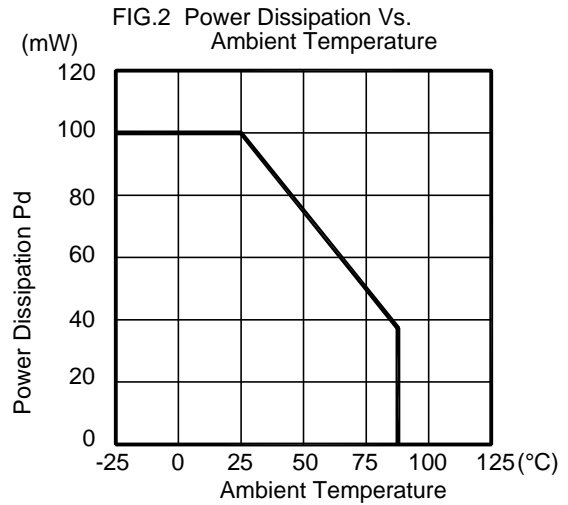
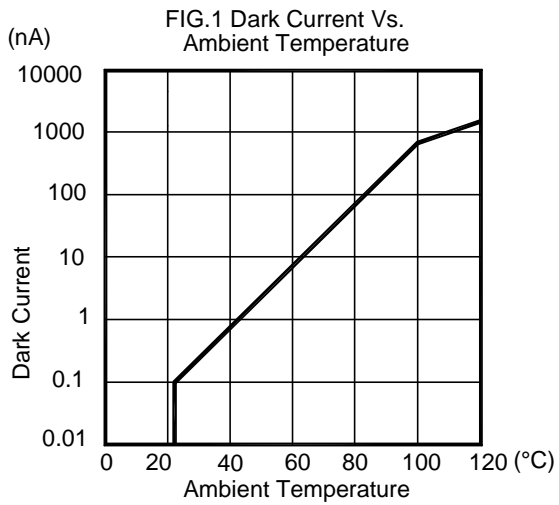

LIGHT

LIGHT ELECTRONICS CO., LTD.

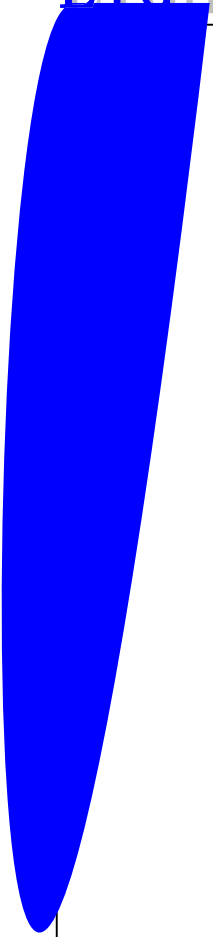

--	--	--	--

LIGHT 深圳莱特光电股份有限公司
 Light Electronics CO., LTD.

TYPE NO. : _____
 QUANTITY : _____
 BIN : _____
 DATE CODE : _____
 REMARKS : _____

LOT NO. : 

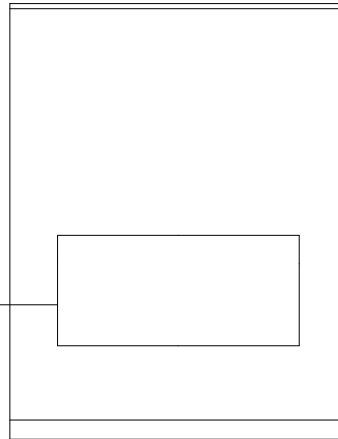

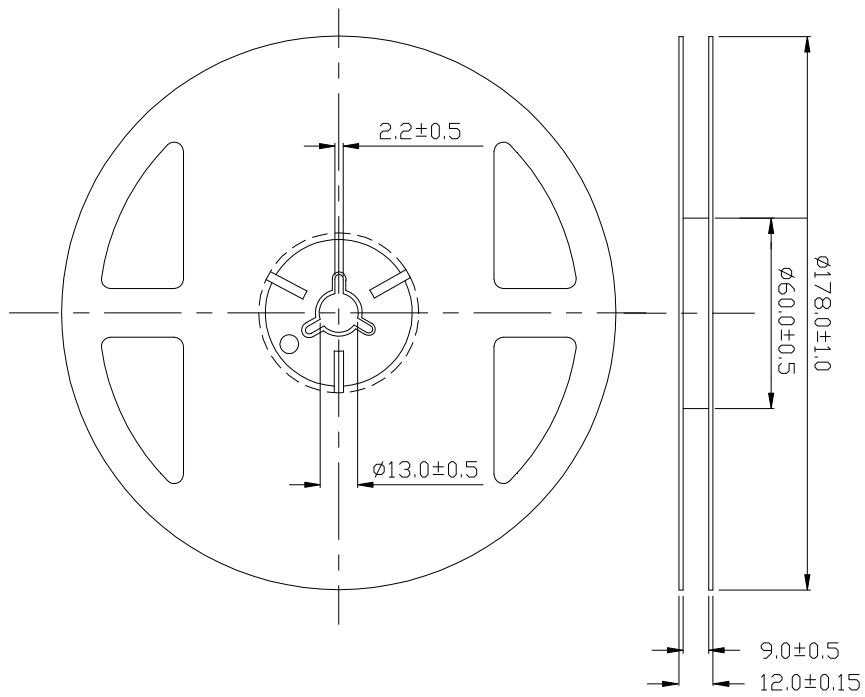

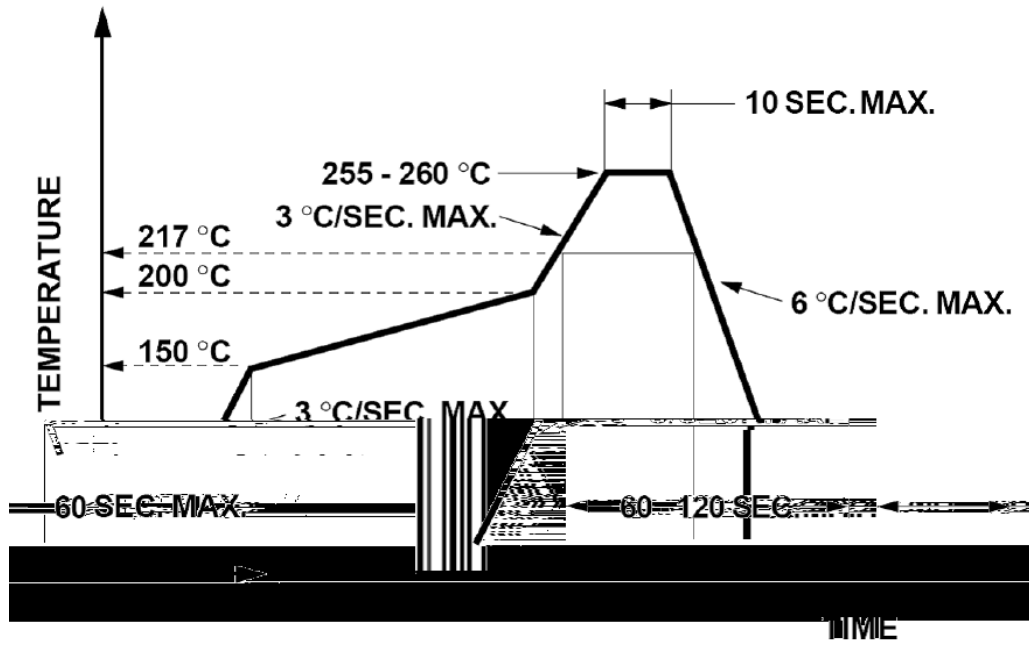

°C

